

Digital Cinema Systems



Presented at Infocomm 2000

by Michael Karagosian

President, MKPE Consulting

Vice Chair, DC28.7 Theatre Systems

© 2000 MKPE Consulting



Elements of Digital Cinema

- Digital Distribution
- Conditional Access
- Storage
- Playback
- Image Projection
- Audio Processing & Amplification
- Action & Effects
- Management System
- Monitoring



Comparison With Traditional Cinema

Film	→	Digital Distribution File
Booth Door Lock	→	Conditional Access
Film Platter	→	Digital Storage
Film Projector	→	Digital Image Projector
Audio	→	Audio



Some Observations

- 38,000 screens in 6,000 US locations
- 100,000 screens worldwide
- Not a Large Market
 - Sales potential too small to develop expensive new technology
- Digital Cinema Will Borrow Substantially from Existing Technology



Digital Distribution

- File-Based Distribution
- Multiple Types of Content
 - Image
 - Audio
 - Subtitle text
 - Action data
 - Metadata

Single File vs Container (Wrapper)

Single File

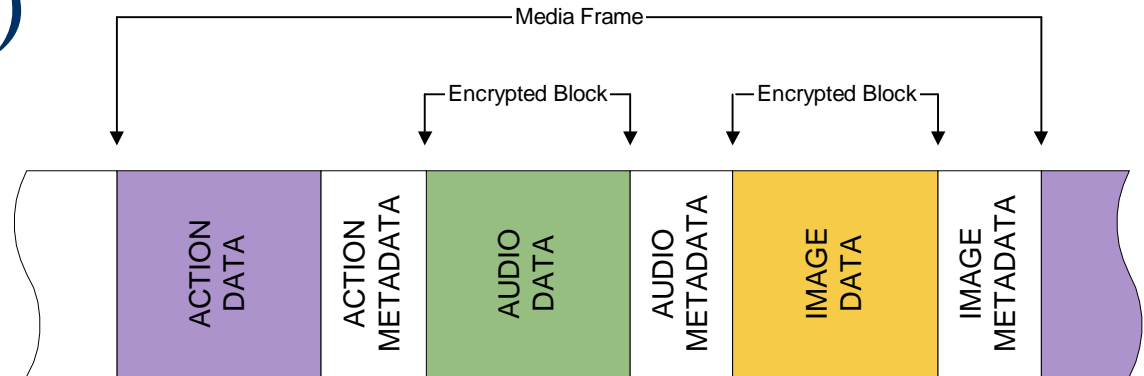

Container

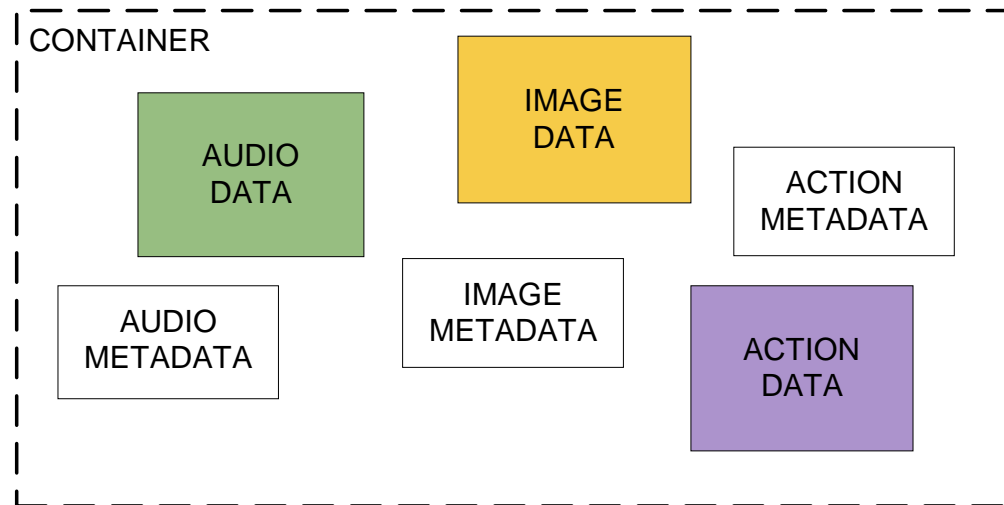



Conditional Access

- Encrypted Distribution File
- “End-to-End” Encryption
- Key Management
 - Symmetrically encrypted distribution file
 - PKI for authorization
- Standards Exist



Storage

- Centralized Storage

- Repository for delivered media
- Backup

- Local Storage for Each Screen

Storage

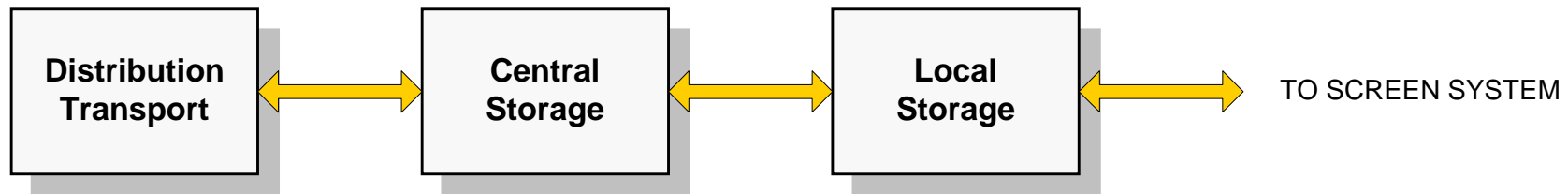



Playback

- Reads the Distribution File
- Outputs Streaming Media
- *Ideally, It Does Little More*
 - *File must be “streamable”*
- Distributed Playback vs Single Playback

Distributed Local Source Playback

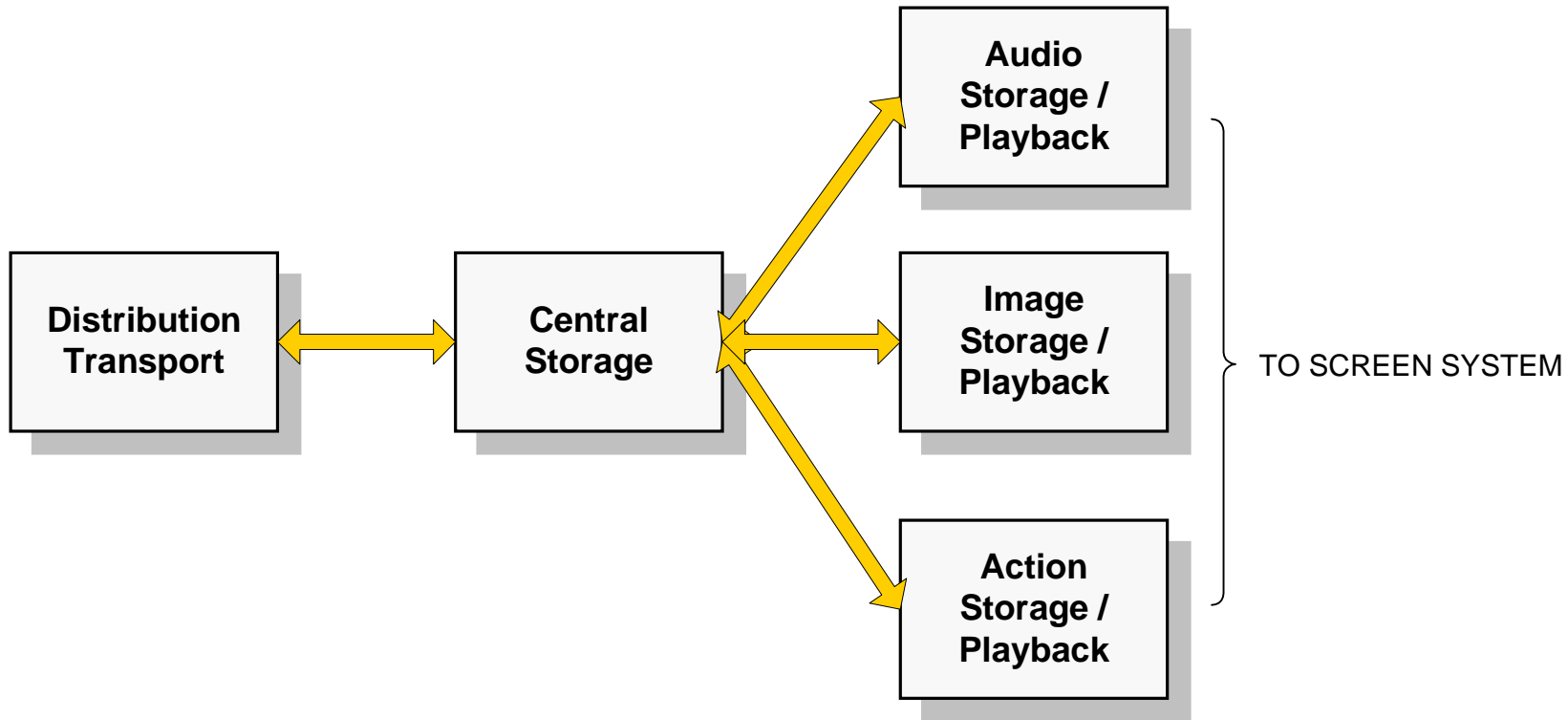

Solo Local Source Playback

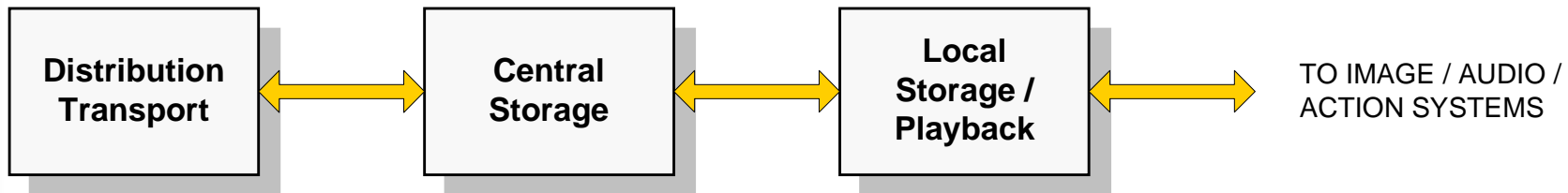

Playback - Streaming Data

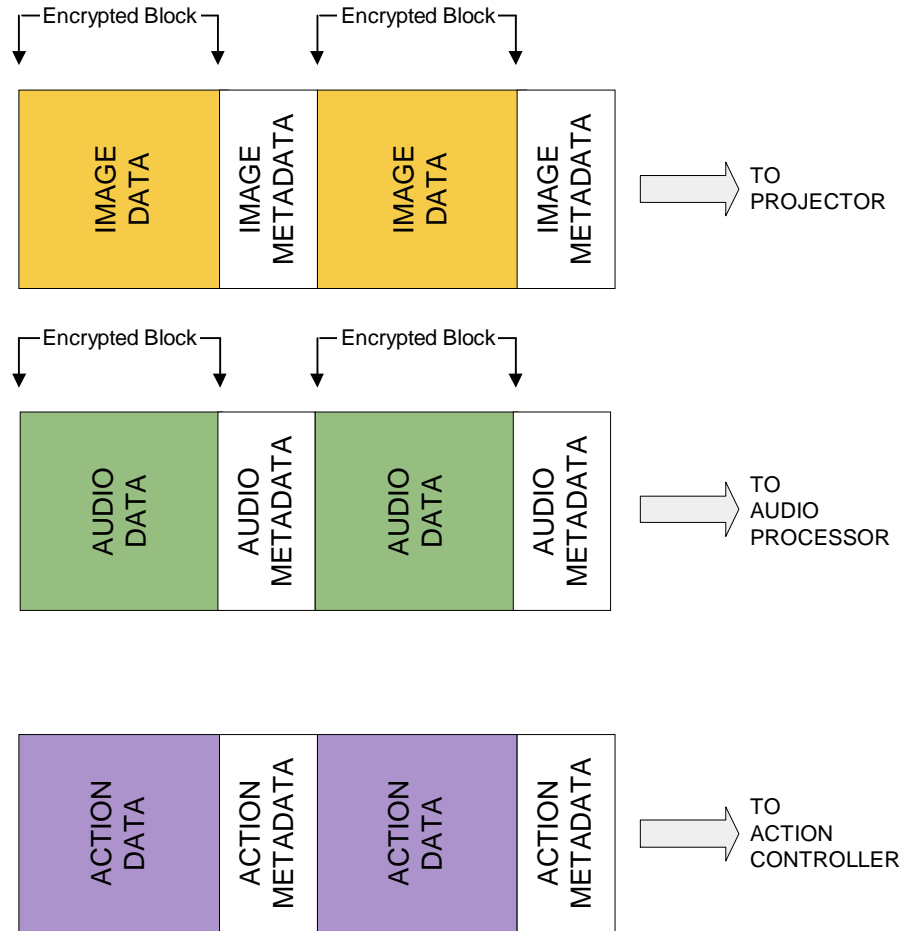



Image Projection

- New Projection Technologies
 - Native resolution varies
 - Colorimetry varies
- Colorimetry and Scaling Correction is Necessary
- “End-to-End” Encryption Ends at the Projector



Audio Processing

- No Compression?

- 6 ch / 48KHz 24-bit audio
→ 16% of file space

- 30% with extra channels for ADA, 6.1, 7.1

- Light Compression Likely

- “End-to-End” Encryption

- Where do we decrypt audio?



Action Control

- Future Stuff: Motion Seats, Figure and Prop Animation, Show Lighting
- Low Sample Rate 8-bit or 16-bit Data
- Examples: MIDI, DMX, Time Code



Metadata

- Metadata is “Data About Data”
- Purpose: Describes Content to Both Humans and Machines
- File Header or Per Frame
- Examples
 - Format ID for image, audio, and action
 - Language ID for audio and subtitles

The System This Far

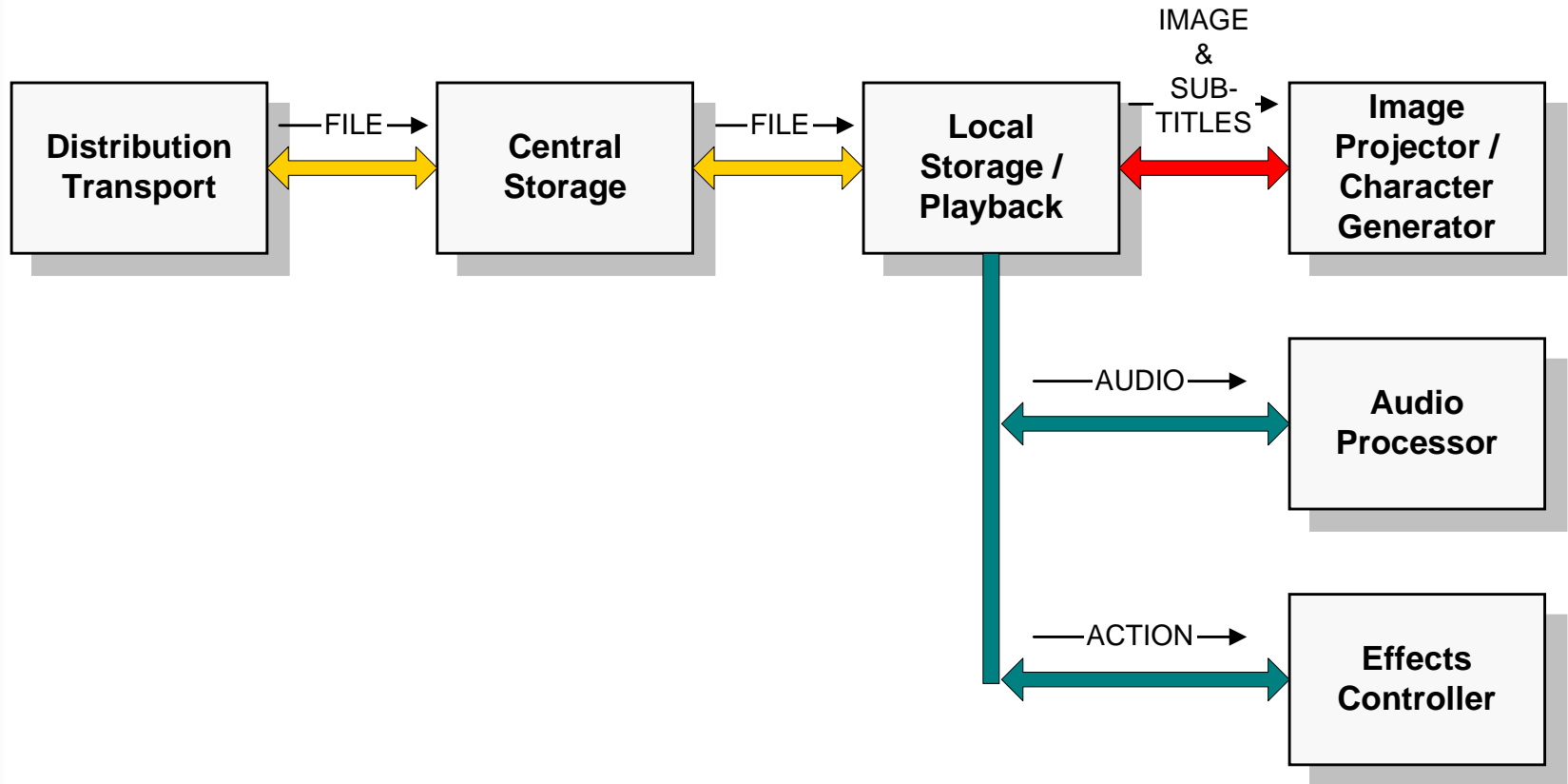



Interconnection

- Networks Will Interconnect Sub-Systems
- Several Network Technologies May Be Used
- Hubs or Switches Will Be Used For Multiple Screens



Monitoring

- Over the Local Network
- Over the Internet
- SNMP An Existing Standard



Theatre Management System

- Key Management
- Show Splicing
 - EDL (Edit Decision List)
for splicing trailers and movie
- Facility Automation
- Monitor Console

The Complete System

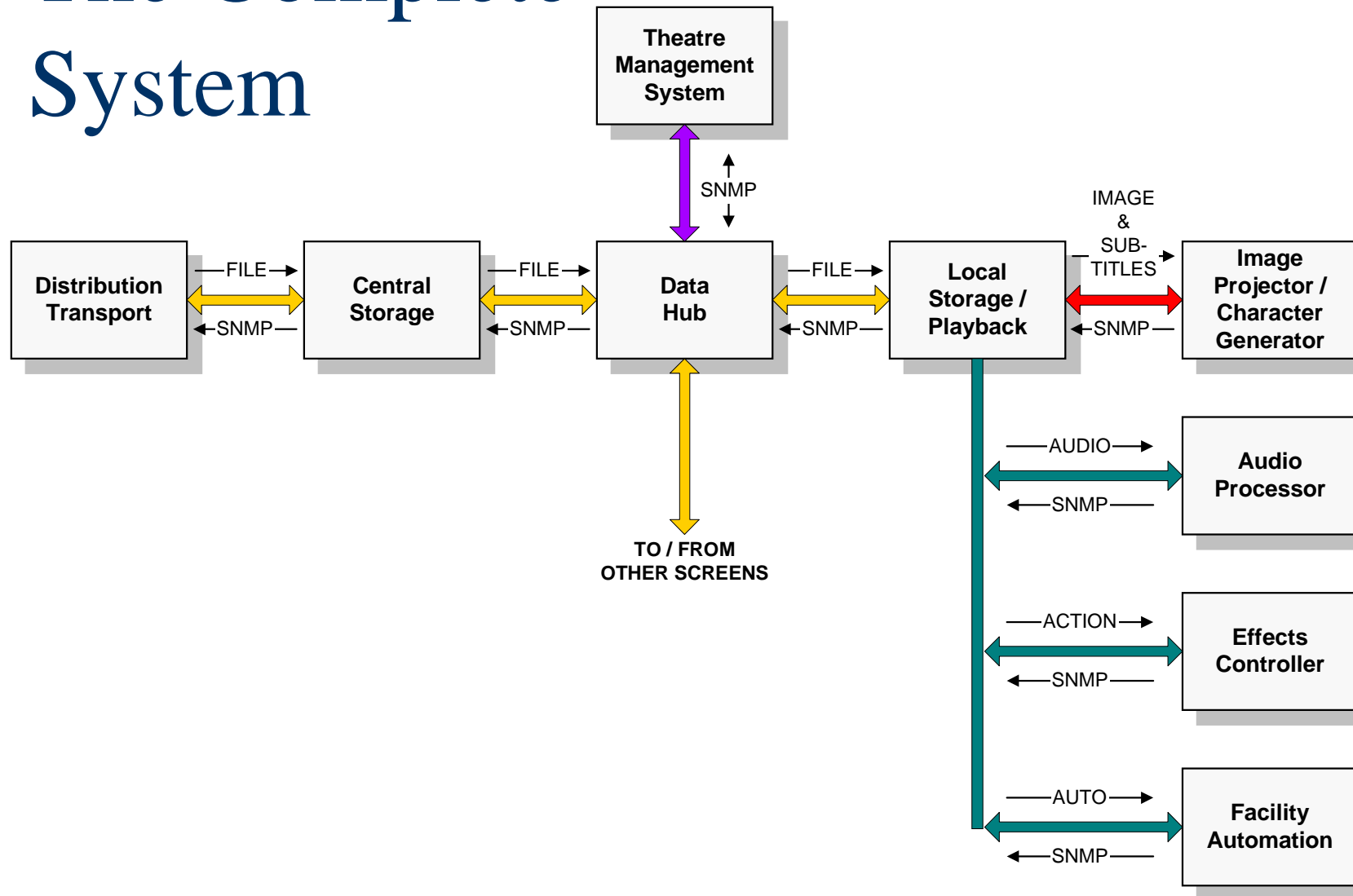



The Big Issues

- File Format
- Compression
 - Renewable?
- Conditional Access / Key Management
- Networks



A word on file format and compression

■ MPEG-4

- “streamable files”
- DMIF: distribution over satellite, comm network, or disc
- AAC audio compression

■ Proprietary Schemes

- May have similar qualities



Scalable & Extensible

- Scalable: Central & Local Storage
- Extensible: Networks
 - Standard 1394a supports IP / SNMP, SCSI, 64 channels of audio, MIDI, etc.



Summary

- Systems are Complex
- Rely Upon Existing Technology
- Standards Exist Today

Contact information

Michael Karagosian

Email: michael@mkpe.com

Web: <http://mkpe.com>

(This presentation is posted at our web site)