

CINEMA D'EUROPA

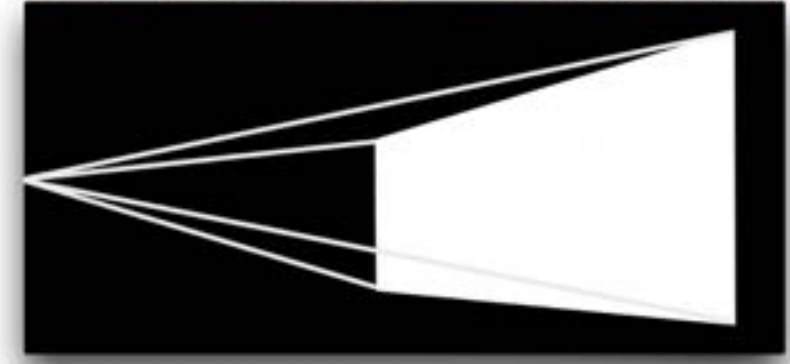

MEDIA SALLES

The Digital Kitchen Sink

DCPs, KDMs, and Accessibility

Michael Karagosian
MKPE Consulting LLC
July 2014



It Starts With The Composition

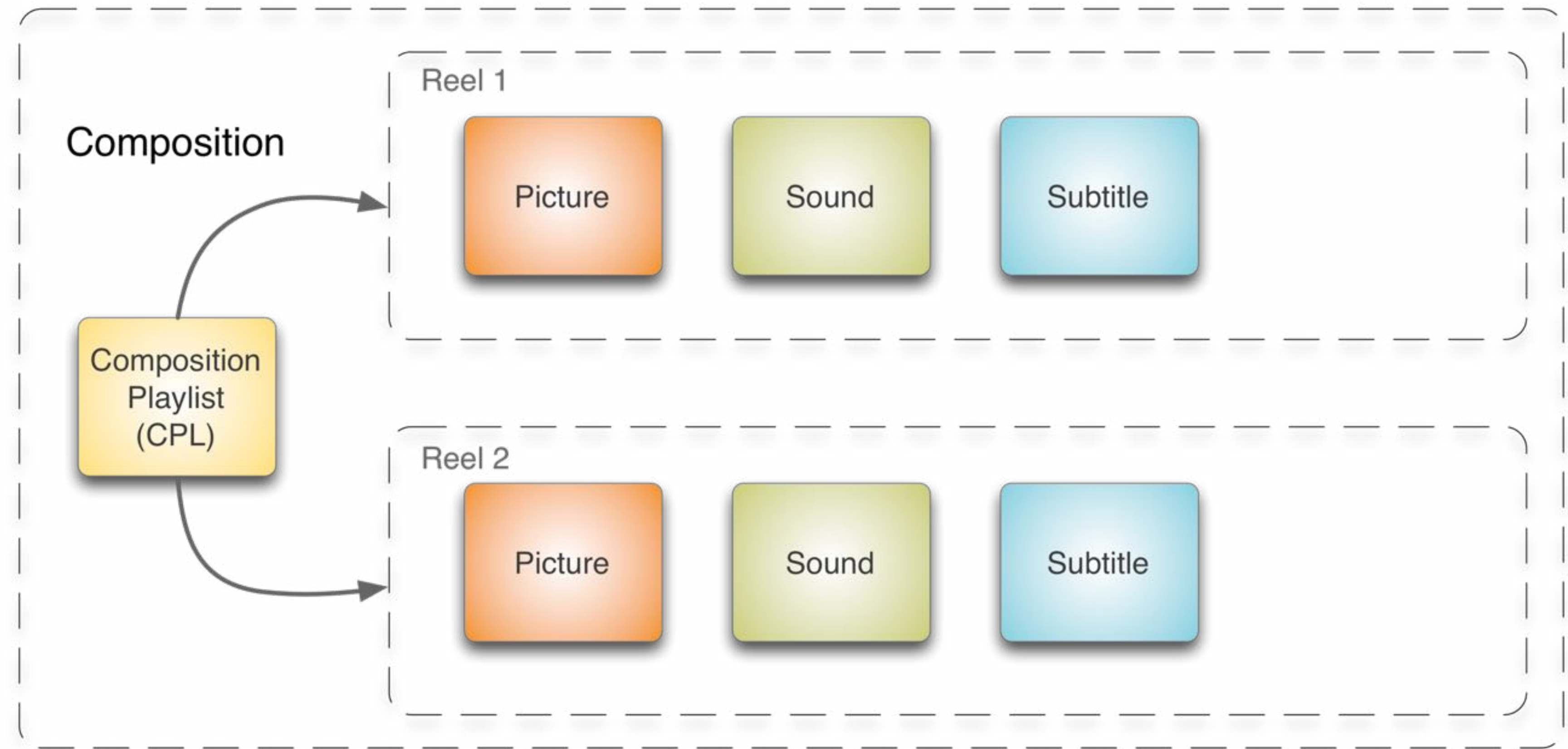

Encrypted Composition

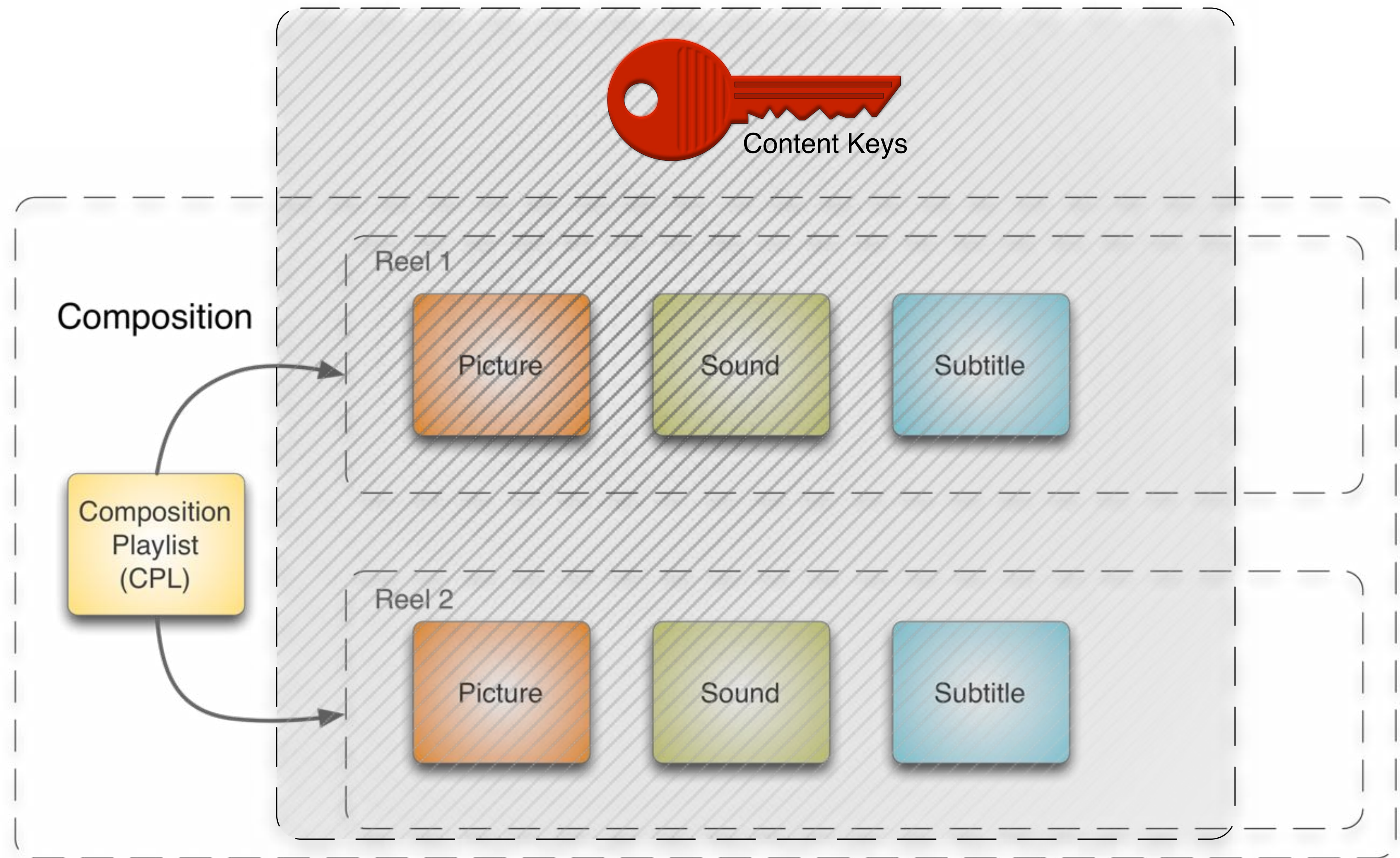

DCP: Digital Cinema Package

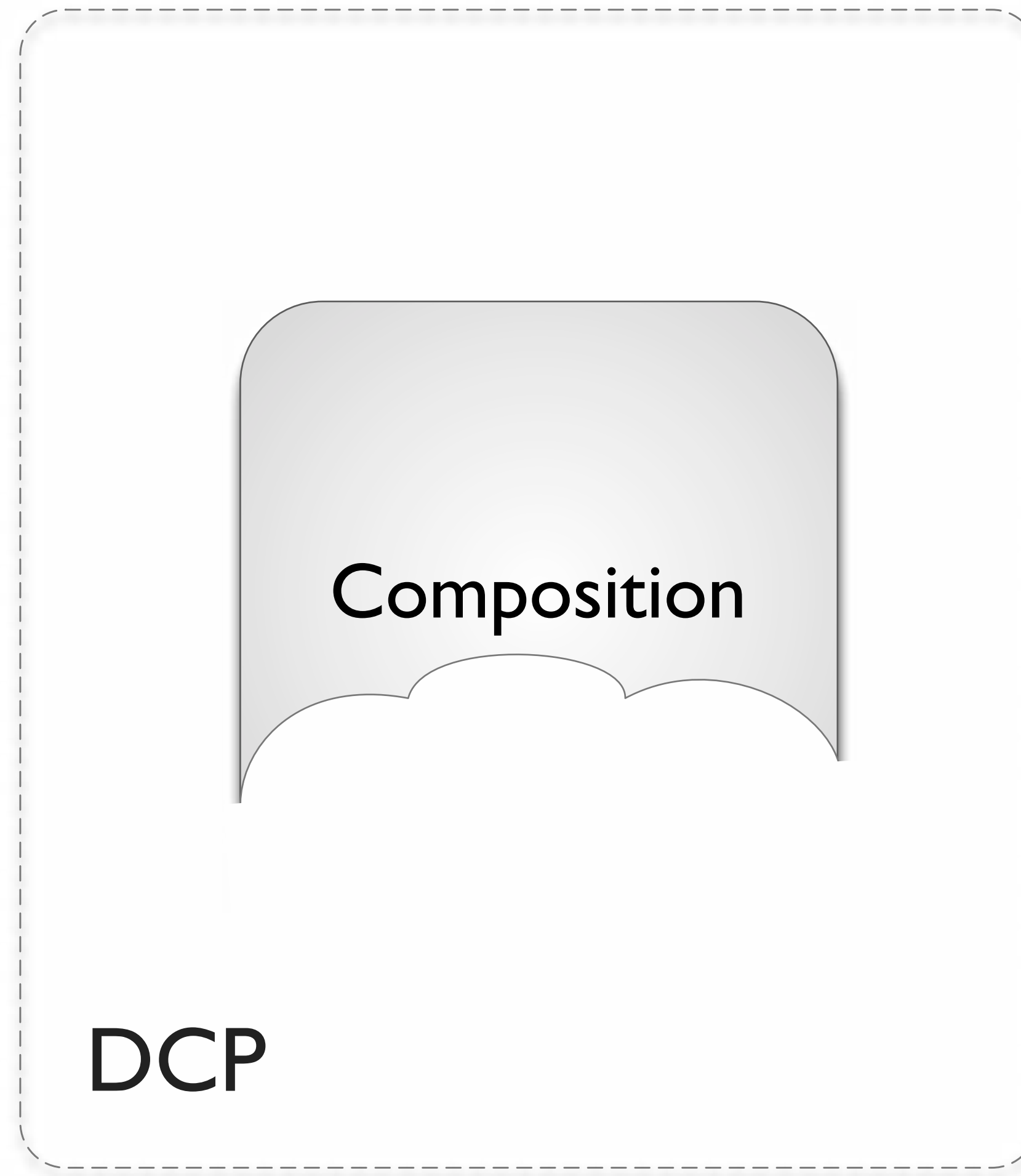
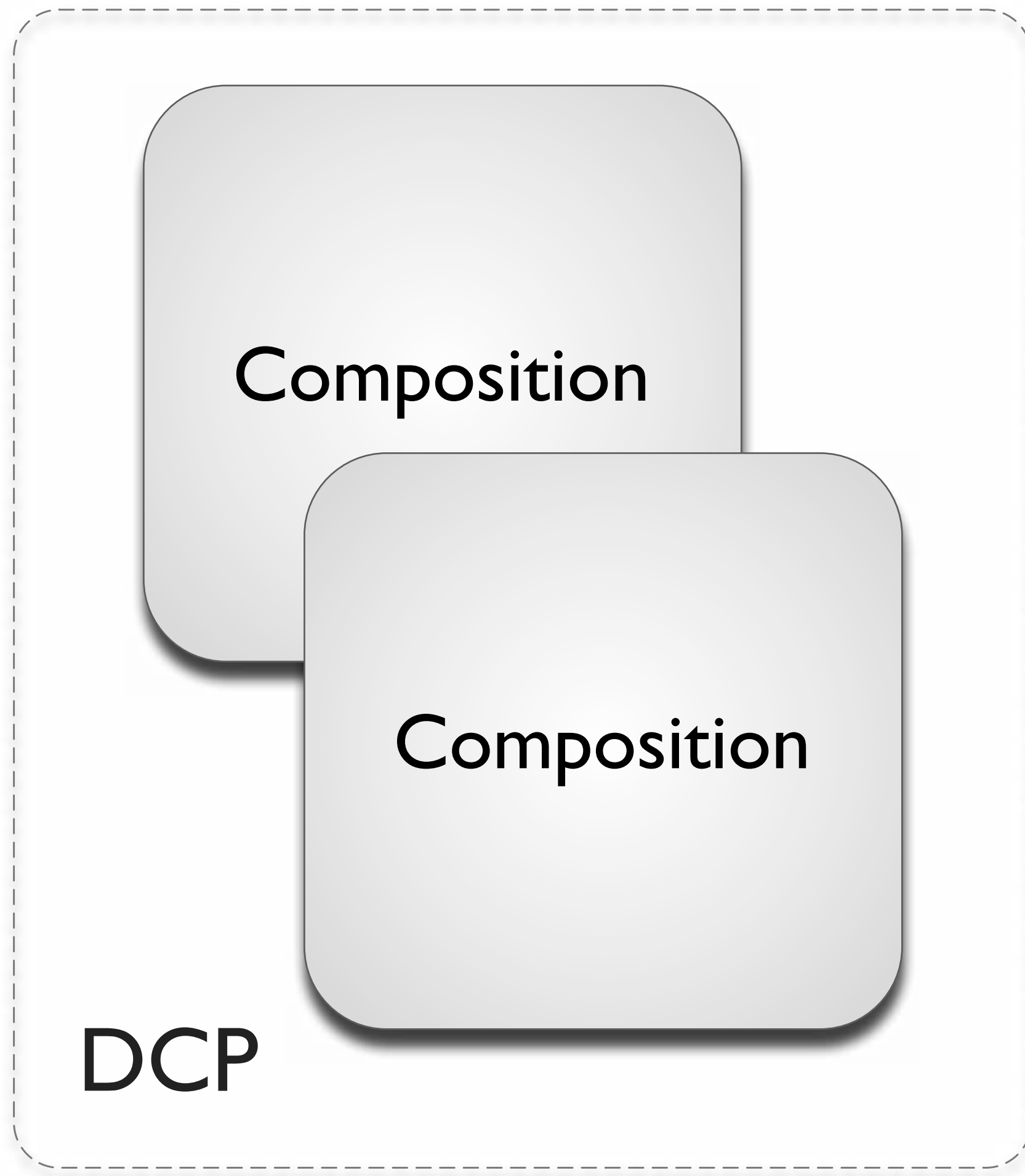

Every
Version
of an
Encrypted
Composition
Requires a
Unique Set
of Content
Keys

Security Key Management In Distribution

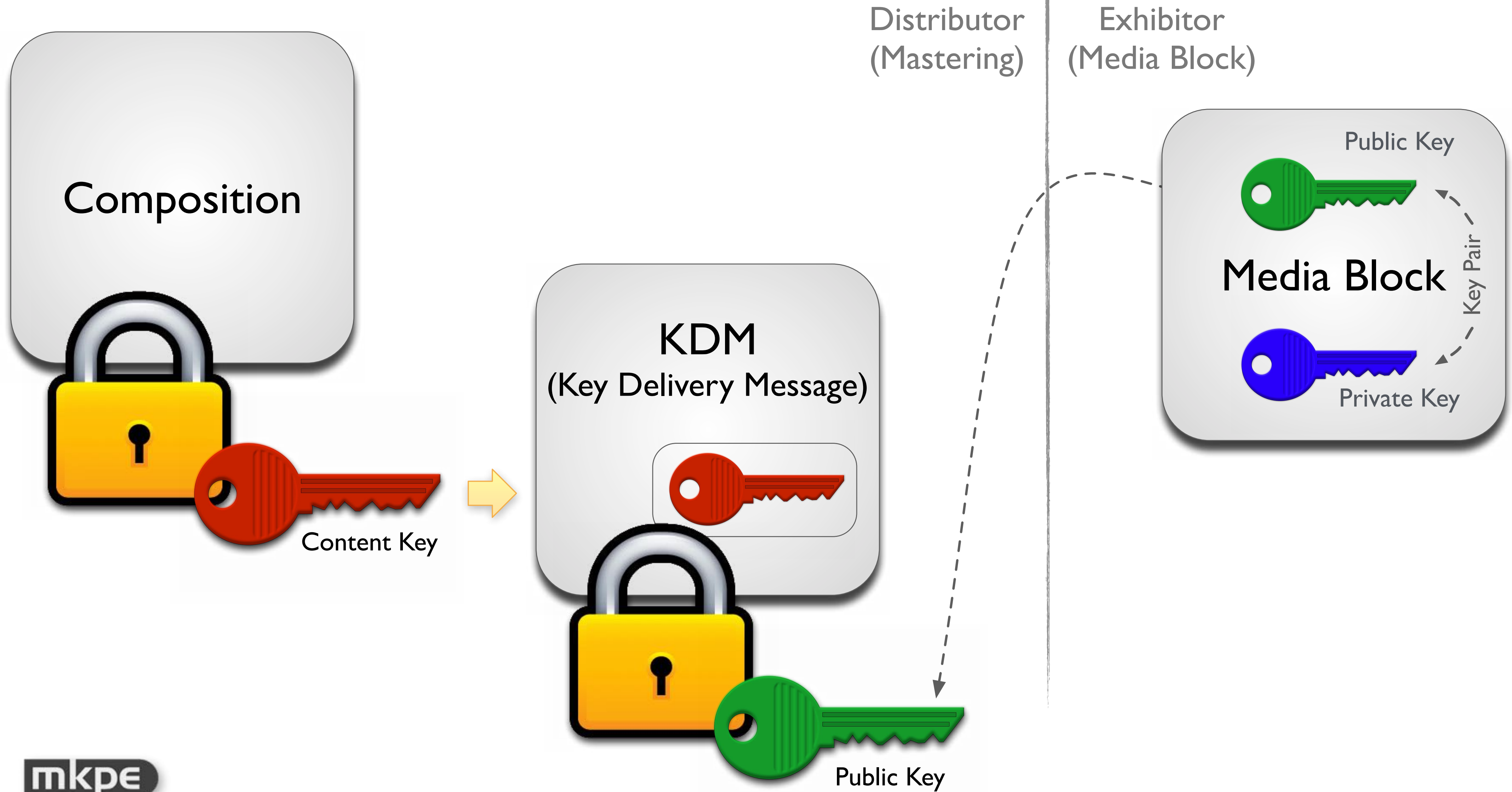

Security Key Management In Exhibition

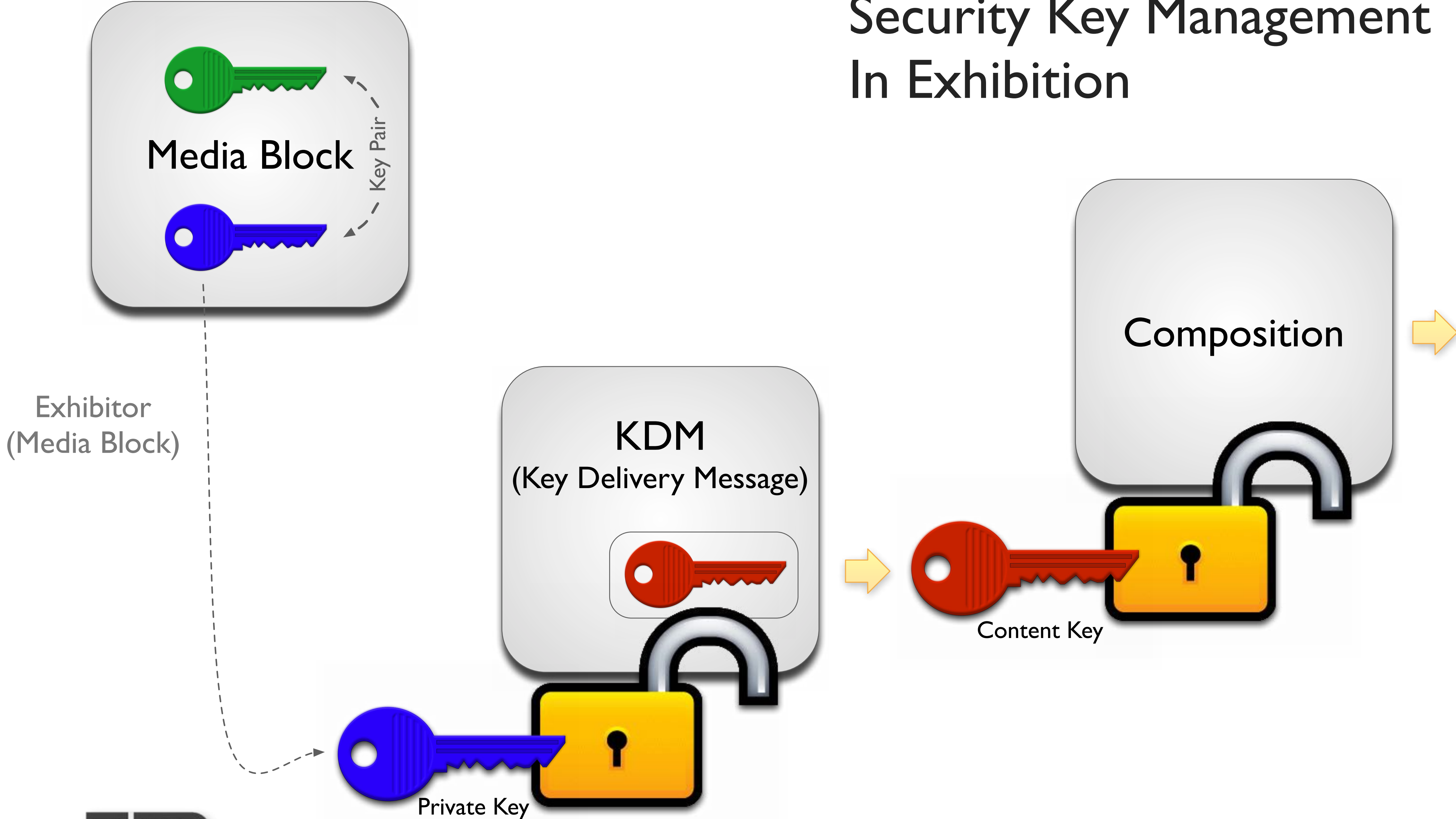

How Does The Distributor Learn The Public Key?



Distributor

Exhibitor

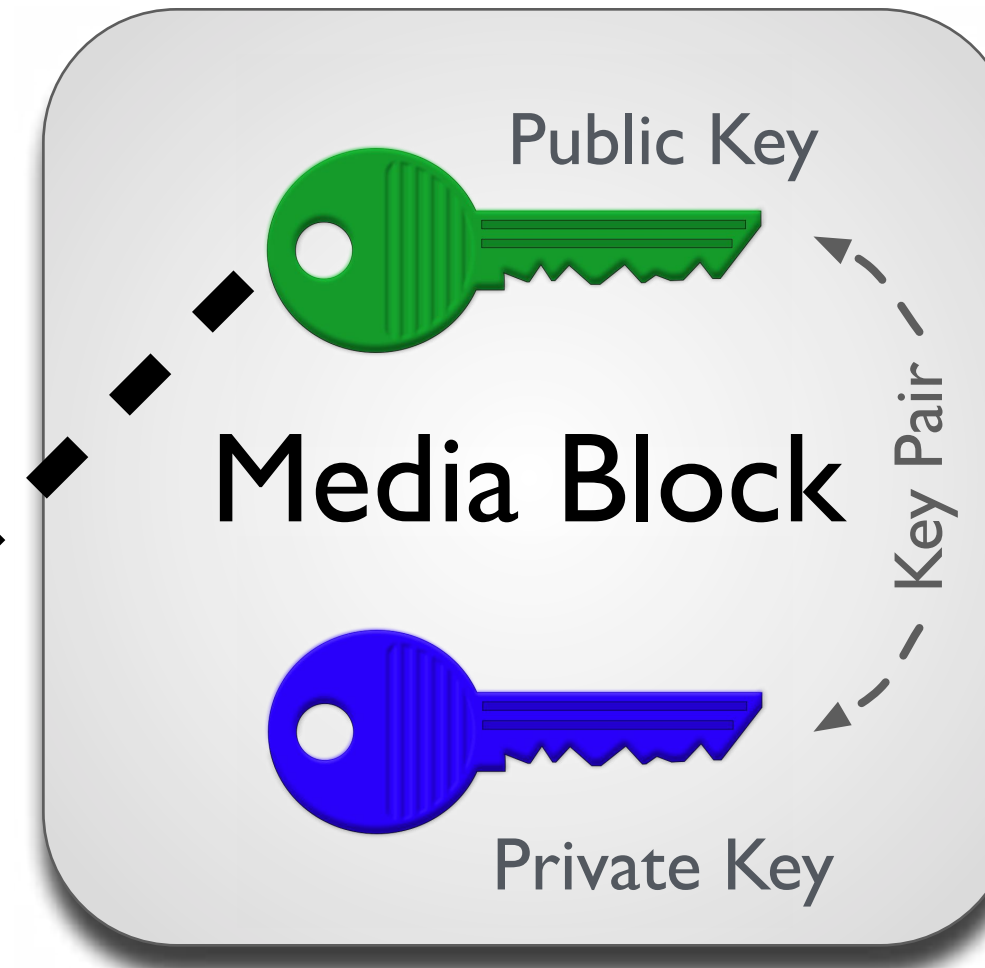

How Does the Distributor Send the KDM?



Distributor

Exhibitor

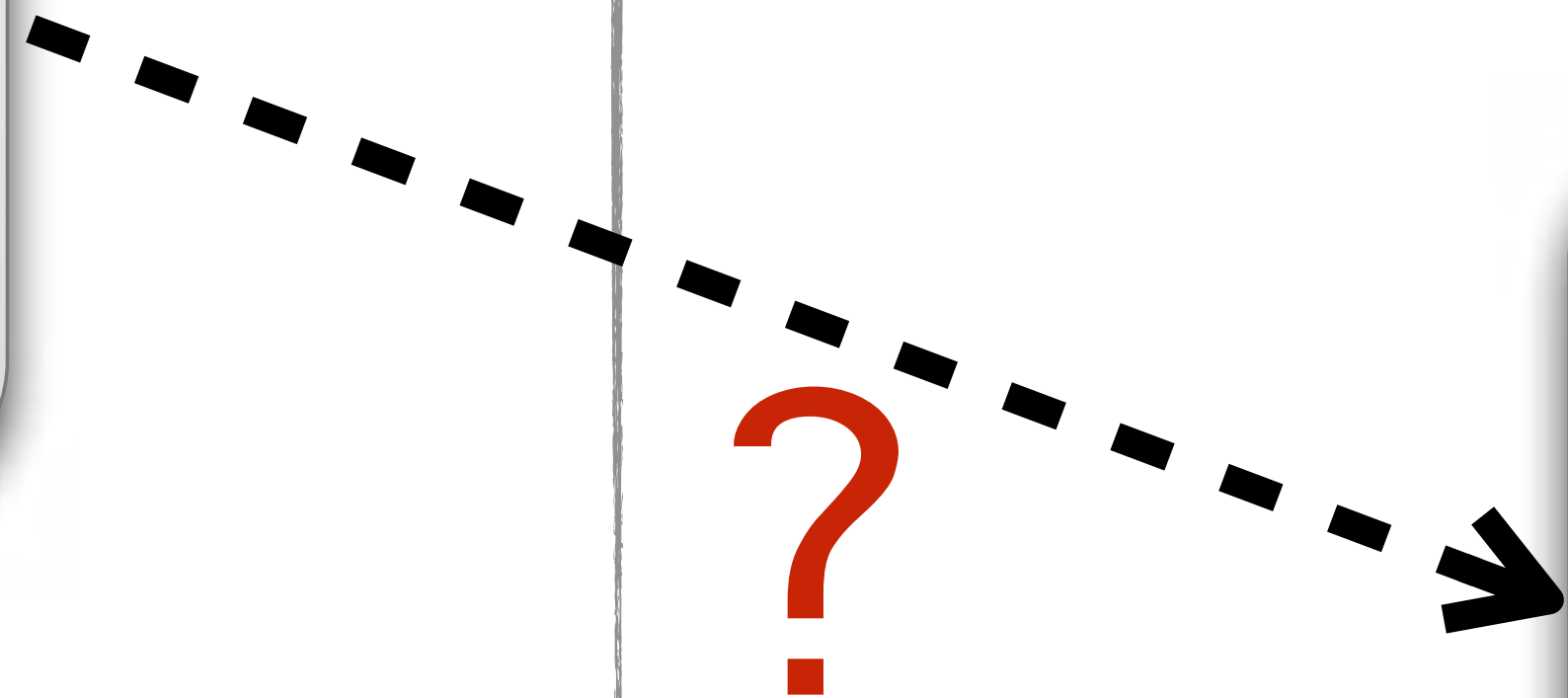
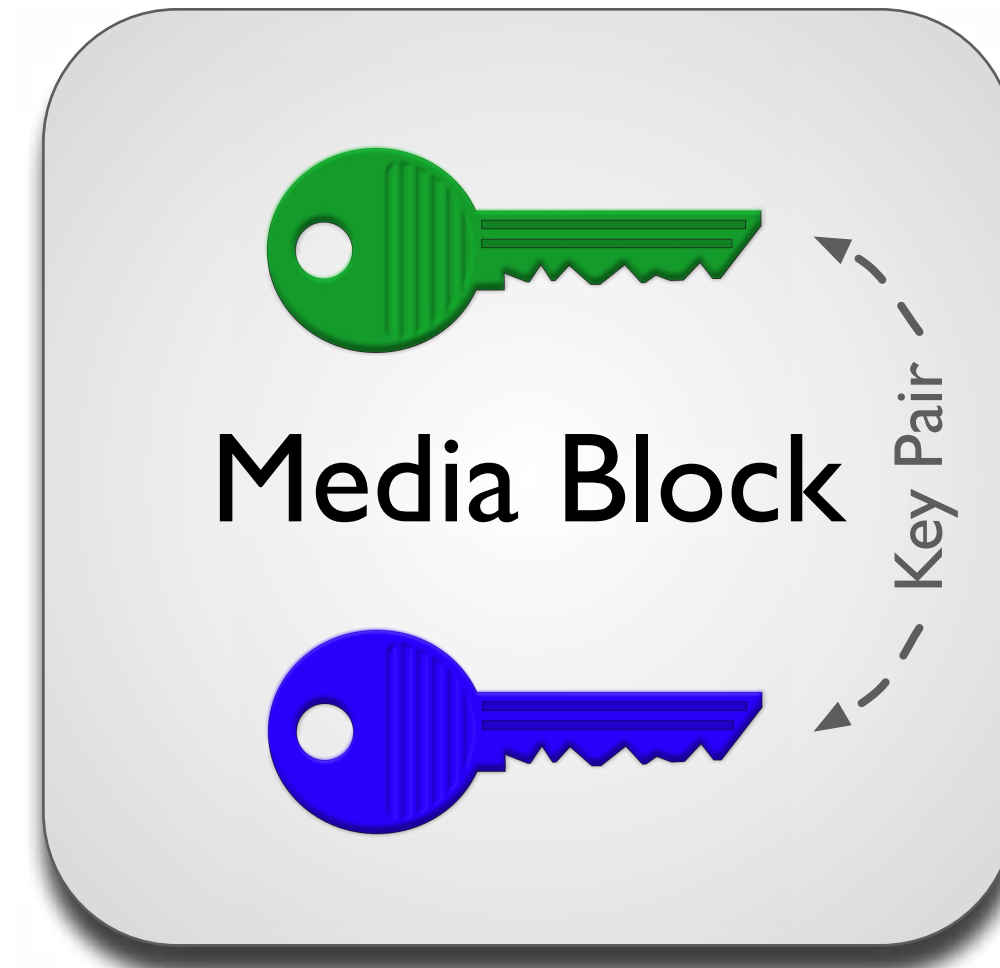

Accessibility



Visually-Impaired Narrative
aka Descriptive Narration
(VI-N)

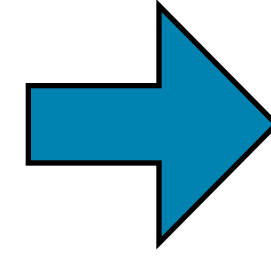

A narrative dialog track for
those who have difficulty with
sight

Hearing Impaired Audio
(HI)

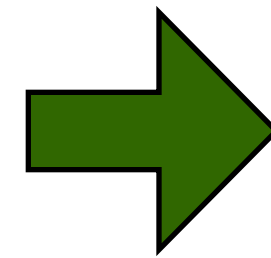

An enhanced sound track for
those who have difficulty
hearing

Closed Captions
(CC)

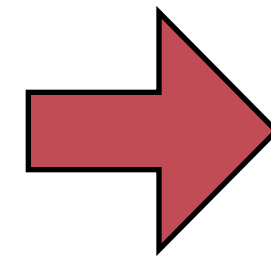

Visual presentation of caption
text for those who cannot
hear or hear well

Hearing Impaired (HI)

- How It Used To Be

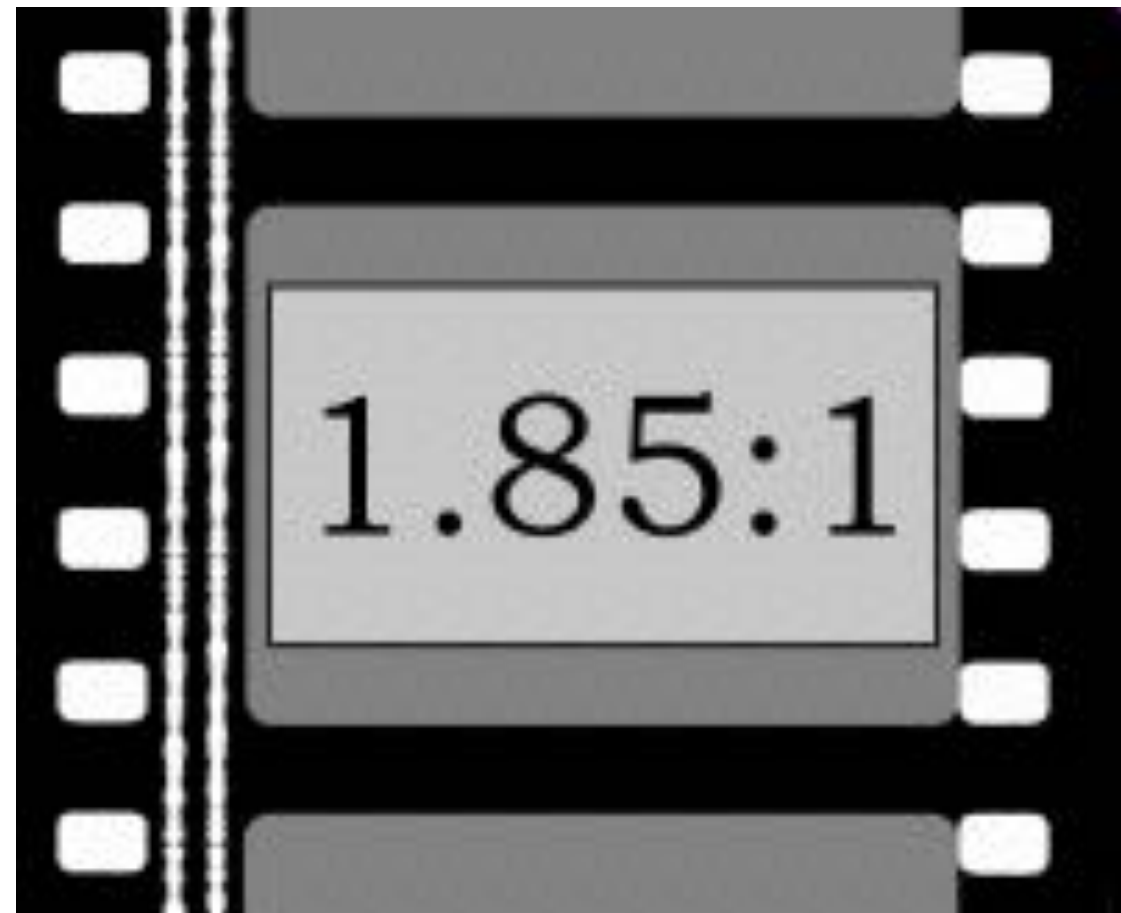

Stereo
Sound

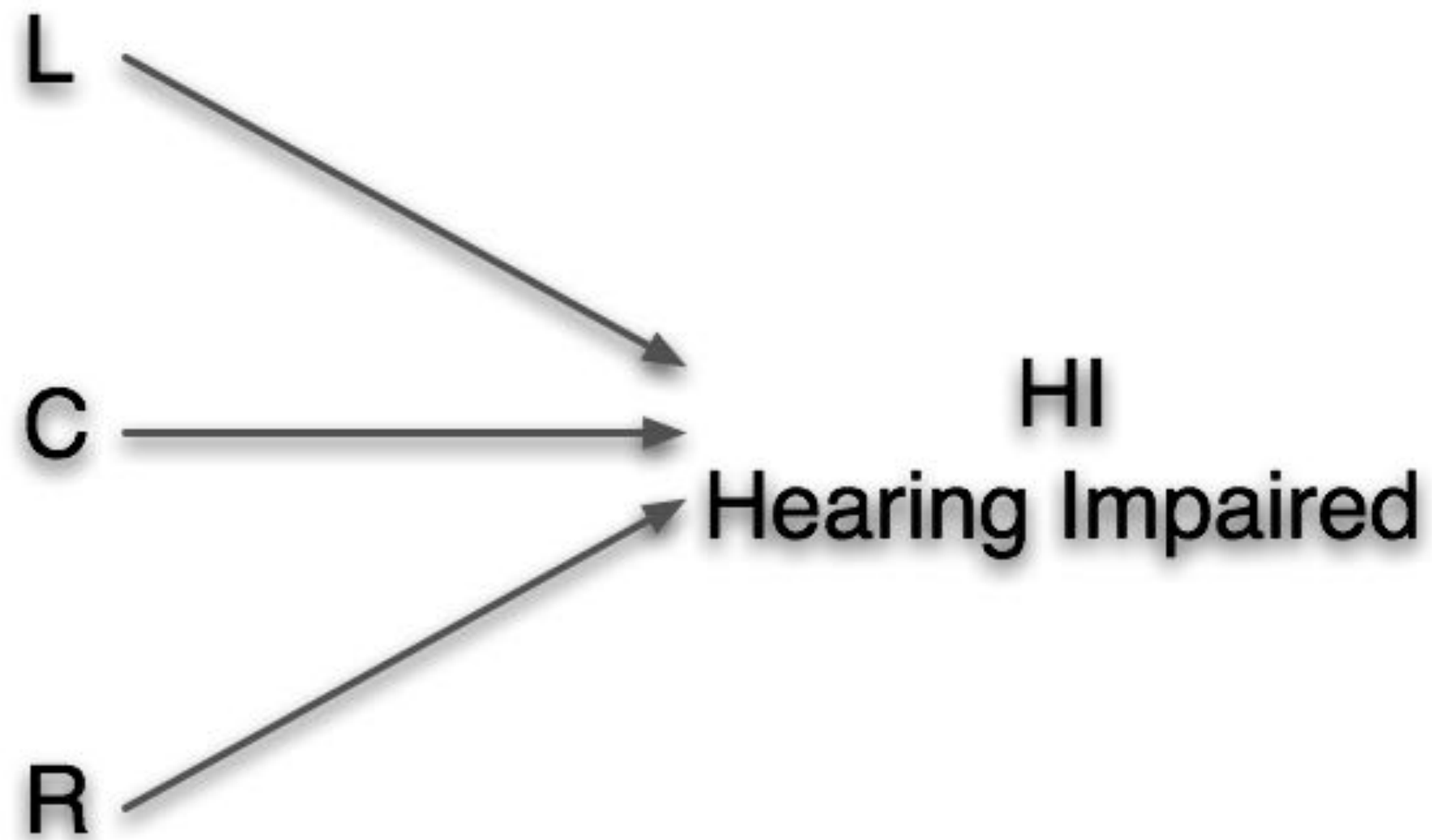

HI Film Signal Was Summed in the
Audio Processor

THIS NO LONGER WORKS WITH
DIGITAL CINEMA

Visually Impaired Narrative (VI-N)

also known as Descriptive Narration

- How It Used To Be

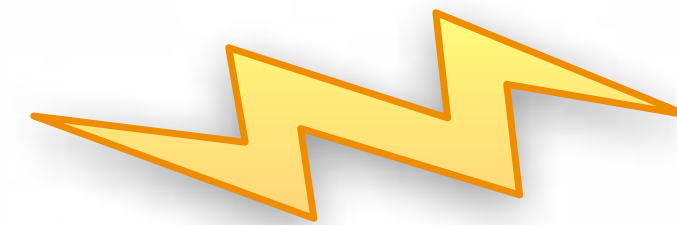

With Film, VI-N was only possible with DTS



Closed
Captions
with Film...

Rear
Window[®]
Captioning
System

Accessibility in Digital Cinema is Based On Open Technology

- Standards-based
- Open distribution
- Open interoperability
- Competitive marketplace
- Lower distribution costs
- Lower installation costs



HI & VI-N With Interop DCP

Container Channel	Configuration			General Loudspeaker Position
	5.1	7.1 SDDS	7.1 DS	
1	L	L	L	Left
2	R	R	R	Right
3	C	C	C	Center
4	LFE	LFE	LFE	Low frequency effects
5	Ls	Ls	Lss	Left surround (or left side surround)
6	Rs	Rs	Rss	Right surround (or right side surround)
7		HI		Hearing impaired (with emphasis on dialog)
8		VI-N		Visually impaired narrative (audio description)
9	--	Lc	--	Left center
10	--	Rc	--	Right center
11	--	--	Lrs	Left rear surround
12	--	--	Rrs	Right rear surround
13		Motion Data		Synchronous signal (currently used by D-Box)
14	--	--	--	<i>Unused at this time</i>
15	--	--	--	<i>Unused at this time</i>
16	--	--	--	<i>Unused at this time</i>

Closed Captions in the Composition

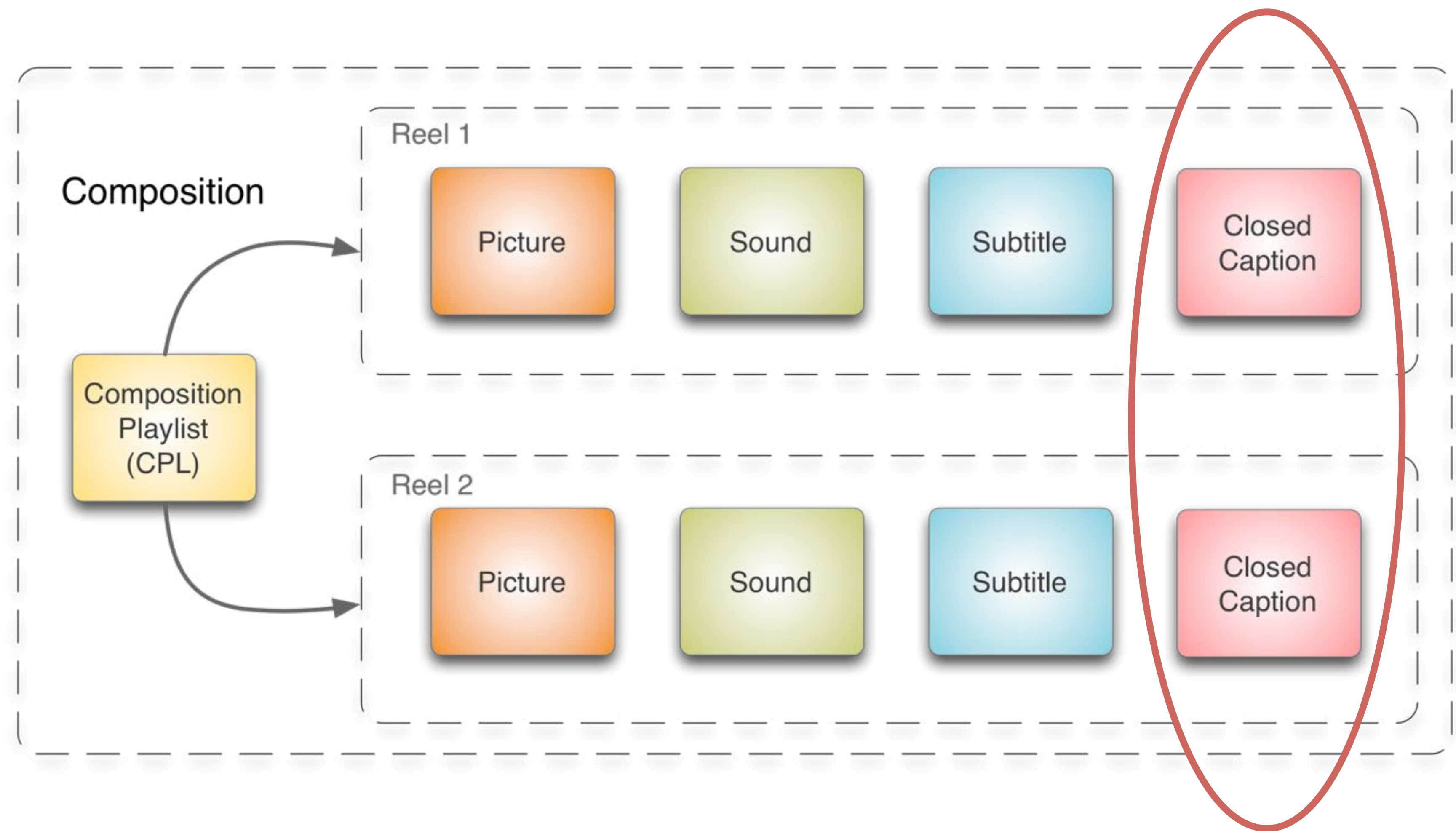

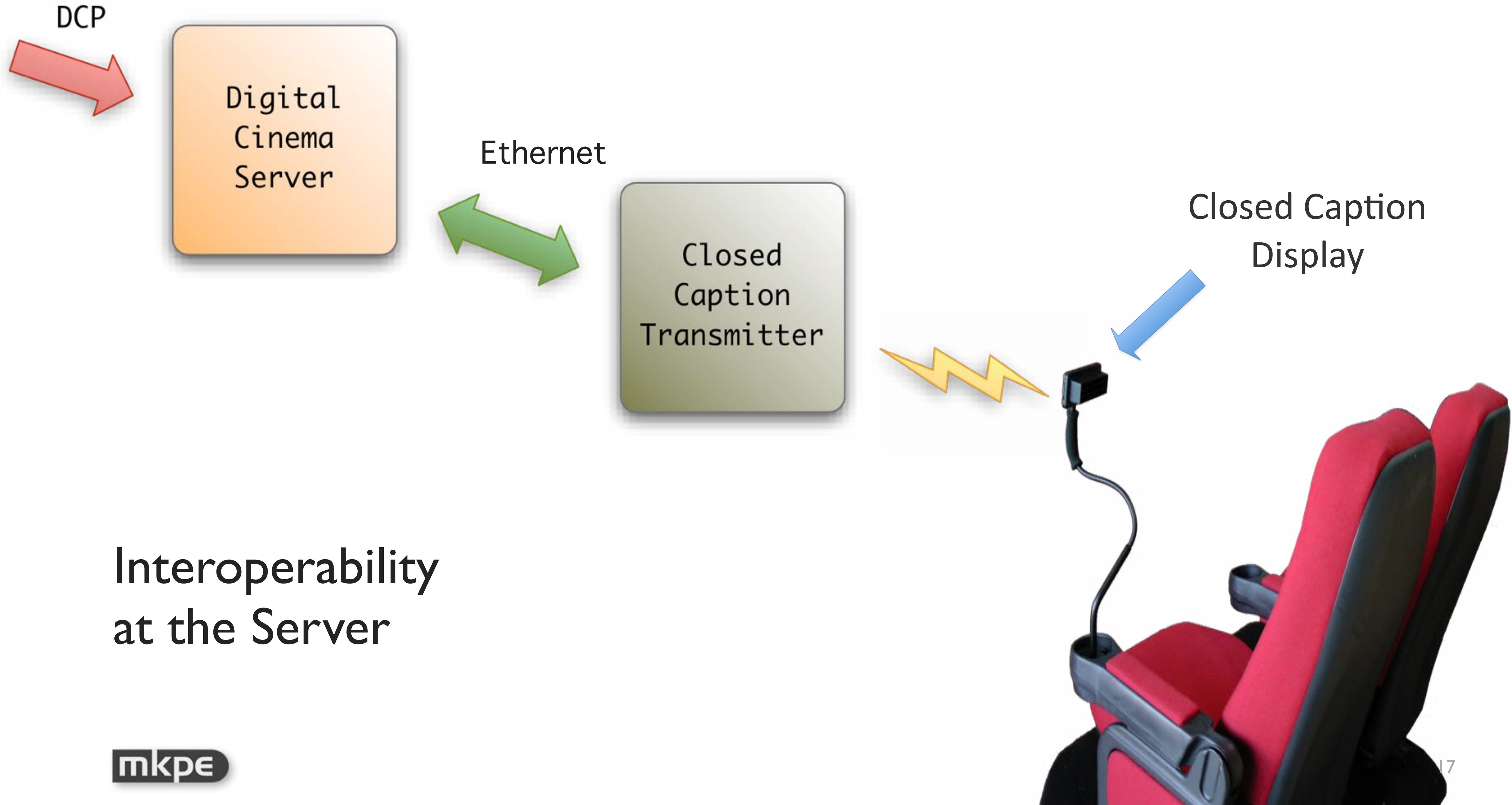

Interoperability
at the Server



CC reader set to auditorium 4
Press A to switch auditorium
or C to connect A C L B

doremi™

mkpe

doremi™



Fidelio™ Architecture

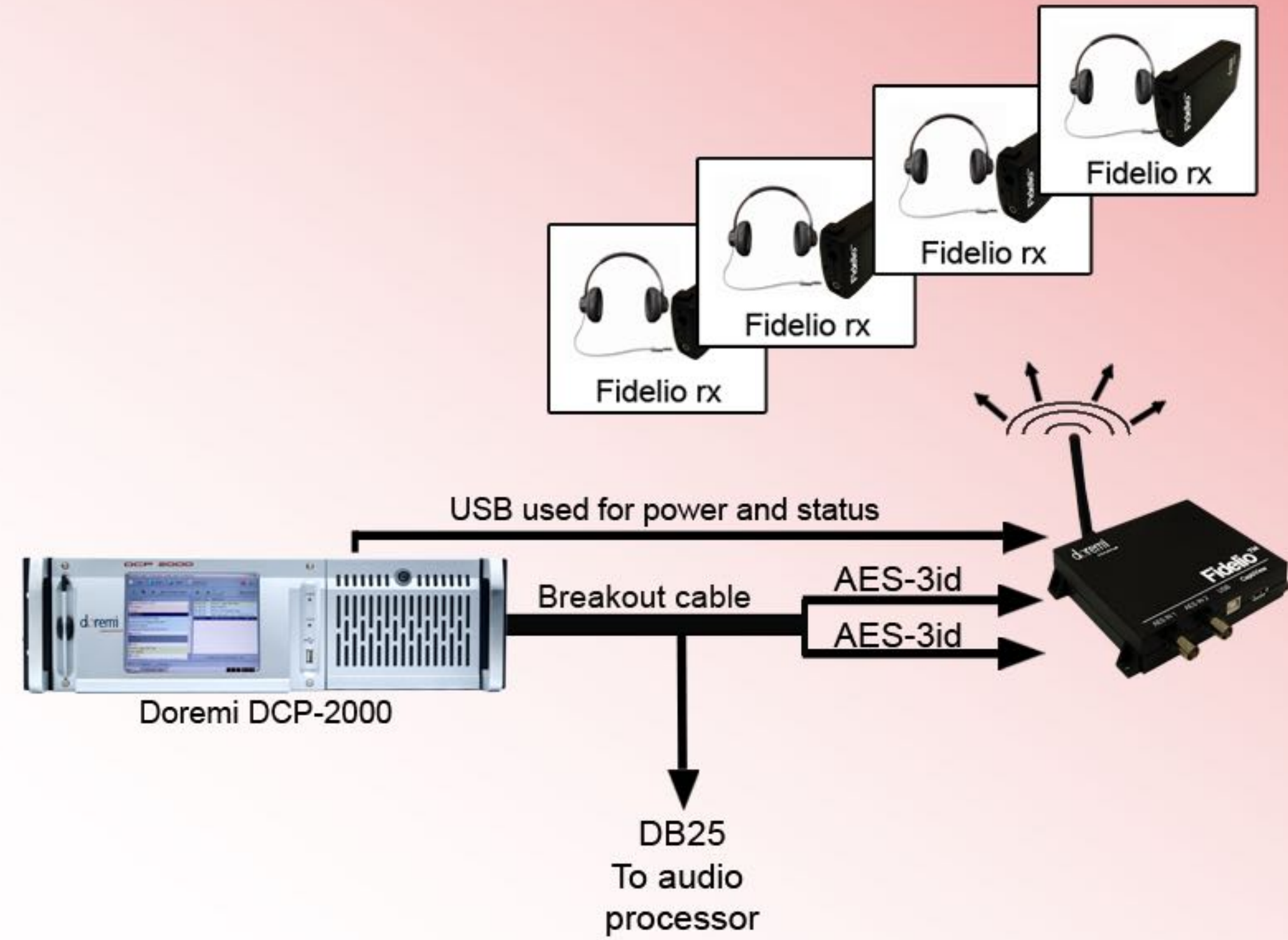



SONY



CINEMA D'EUROPA

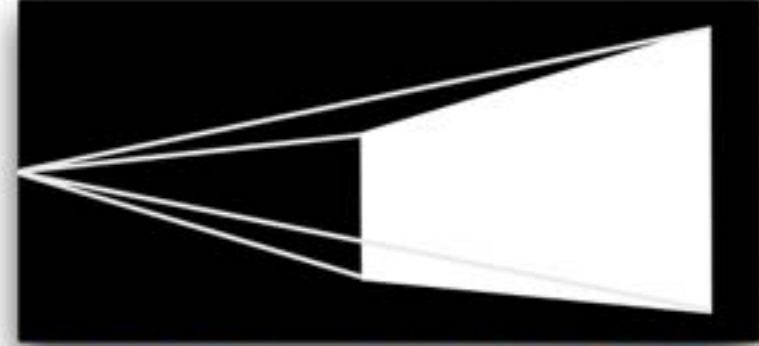

MEDIA SALLES

Michael Karagosian
MKPE Consulting LLC
Calabasas, CA USA
michael.karagosian@mkpe.com

mkpereport.com

mkpe.com



mkpeReport free for 2months (\$80 discount) with this Coupon: MEDIA-SALLES-2014

mkpe